



Single Phase Voltage Relay

SVM

Specifications

Electrical

Nominal Voltage: 50/60 Hz

- 11 to 15VAC
- 22 to 27VAC
- 100 to 130VAC
- 200 to 250VAC
- 350 to 420VAC
- 11 to 15VDC
- 22 to 27VDC
- 28 to 32VDC
- 42 to 55VDC
- 60 to 100VDC Consult Factory

Over/Under Voltage:

±10, 13, or 16% of Nominal Voltage

Hysteresis: 2%

Pick-up & Drop-out Delays:

0.5 sec. fixed

Power Consumption: 1.5VA

Output Rating @ 25°C:

- 10 Amps @ 250VAC
- 1/2 HP @ 250VAC
- 1/3 HP @ 125VAC
- 10 Amps @ 30VDC

Physical

Mounting: Plug-In

Termination: 8 Pin Octal (Over 300V requires use of OT-08 socket.)

Packaging: Dust Cover

Weight: 9 Oz.

Ambient Temperatures

Operating: 0°C to 40°C

Storage: -40°C to 85°C



Ordering Information

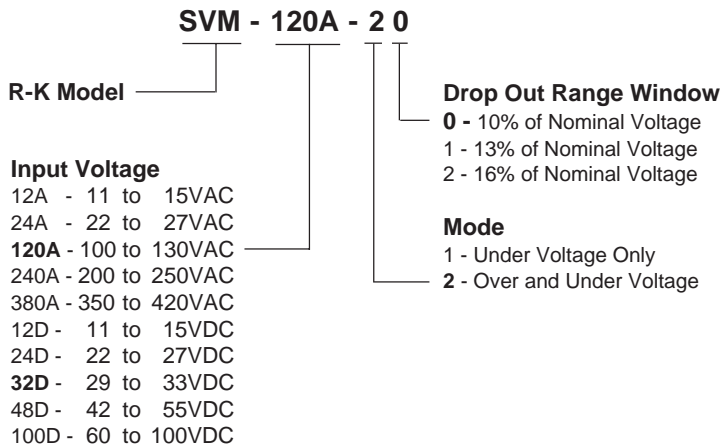

- AC or DC Voltage Monitor
- Over & Under Voltage
- Single Knob Adjust
- 10Amp Contacts NC/NO
- Nuisance Delay
- Compact Design
- Low Cost



Operation

Nominal Voltage Monitor

The SVM monitors single phase AC or DC voltages and operates a set of dry contacts. Several voltage ranges are available. The control is set to the nominal voltage and the relay will drop out when the percentage over or under voltage condition is reached. The LED lights when conditions are normal and the output relay is energized. A time delay controls the effects of short term voltage variations. Fixed delay is 0.5 second.

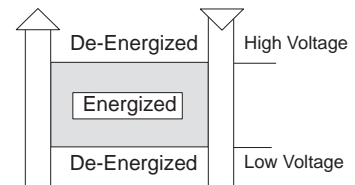

Connections

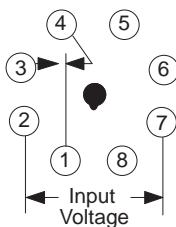

Dimensions

