



Zero Speed Switch

ZVM-600

Specifications

Electrical

Input Voltage: 115VAC \pm 10%
Frequency: 50/60Hz
Set Point Range: Adjustable
Adjustable: 40 to 400 millivolts
Differential: 1 millivolt, Approx.
Overvoltage:
 Accepts up to 600 Volts on signal terminals
Signal impedance:
 100,000 Ohms, Minimum
Response Time: Pick-Up of Relay with
 Decreasing Voltage: 0.5 Sec. Fixed
Power Consumption: 5VA
Output Contacts:
 1/3 HP @ 120/240VAC
 10 Amps @ 120VAC
 100,000 Full Load Cycles
 50,000,000 Mechanical Cycles

Physical

Mounting: Surface
Termination: Screw Terminals
Packaging: Open Printed Circuit Board
Weight: 11 oz. Approx.

Ambient Temperatures

Operating: 0°C to 65°C
Storage: -30°C to 85°C



Ordering Information

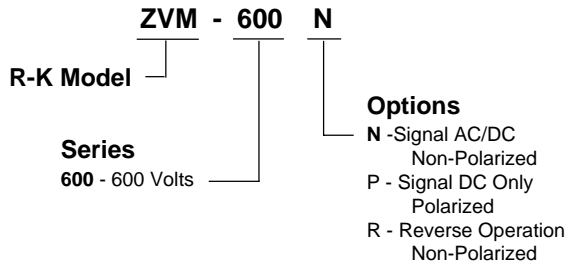

- Low Profile
- 10 Amp, DPDT
- Millivolt Sensitivity
- 600 Volt Max. Signal Overvoltage

Dimensions

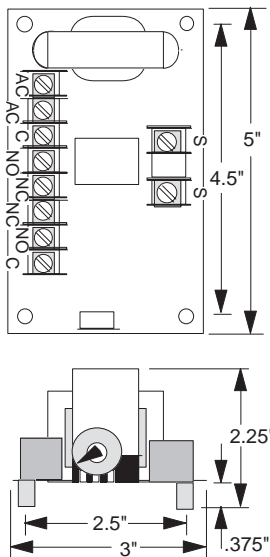

Connections

For Zero Speed sensing the ZVM should be connected to the line voltage on the load side of the starter (MS).
 M = Motor MS = Motor Starter
 OL = Overloads
 Fuses = \leq 1 amp (optional)

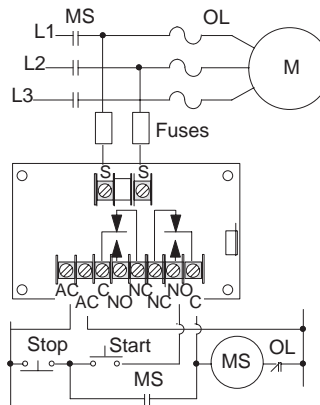

Operation

An AC input voltage of 115VAC must be provided to the ZVM continuously. While the ZVM will drop-out and pick-up based on an adjustable millivolt set point, the signal circuit will accept up to 600VAC. With no voltage on the signal terminals, the internal relay is energized, transferring the output contacts. When the voltage exceeds the set point, the relay will de-energize. When used on Zero Speed applications, a loss of input voltage will cause the relay to remain de-energized as if the motor were still running. Reverse operation is available. For DC current sensing, select a 100mV shunt of the correct current rating and connect the shunt in series with the load and in parallel with the ZVM's signal terminals.

